

Rasonic
樂信牌

RSS-T08GC

迷你電子燉盅 Mini Electric Stewing Mug

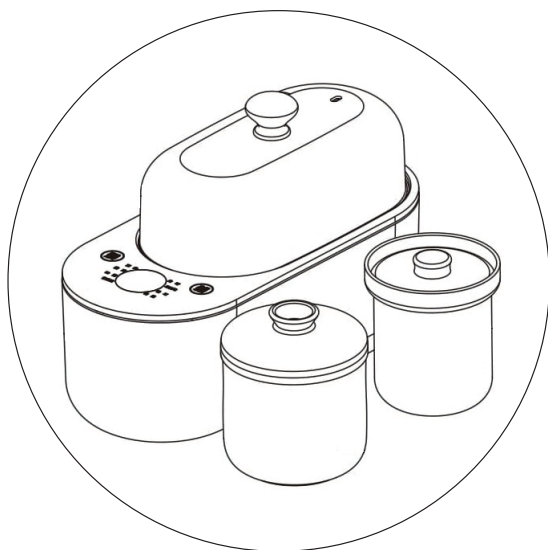

僅適用於家庭使用
For household use only

使用說明書

OPERATION MANUAL

- 在使用本產品前，請仔細閱讀本說明書，閱讀後小心收藏，以備日後查閱。
- Please read the operation manual carefully before using. Keep it in a safe place for future reference.
- 本說明書中的圖示可能有與實物不同的地方，僅供參考。
- Some figures in this manual may not match with the real object, just for reference only.

非常感謝您選購樂信牌迷你電子燉盅，使用前請先詳細閱讀本說明書，並保存以備日後參考。

目錄

1. 安全注意事項
2. 清潔及保存
3. 產品規格
4. 控制面板及產品結構
5. 使用方法
6. 故障排除
7. 特別聲明
8. 售後服務

1. 安全注意事項

使用本產品時，必須遵守下列安全措施：

1.1 使用前

1. 仔細閱讀相關的說明，不遵循或忽視這些安全注意事項，有可能導致火災、觸電或個人傷害。
2. 將所有包裝物料全部取出並棄掉，以免兒童當作玩具造成危險。
3. 檢查本地電壓是否與產品額定電壓相符，將插頭插入合適的插座上。切勿與其他高功率的電器共用同一插座，以免電力負荷過重。同時，插座亦必須接駁地線。
4. 接駁電源前，須確保機體表面及插頭已充分擦乾，以免造成危險。

1.2 使用時

1. 切勿讓本產品在無人看管或注水格沒有水的情況下運作。
2. 切勿直接於注水格(發熱盤)內加熱食物。
3. 切勿在以下環境使用本產品：
 - 潮濕或接近水源的環境；
 - 靠近熱源及火源(如焗爐及電磁爐等)；
 - 不平整或承托力不足的表面；
 - 易燃物料或不耐熱物品附近(如地毯、塑膠枱布、窗簾及毛巾等)。
4. 注水格內必須預留足夠空間容納蒸氣及氣泡，以防滿溢。如注水太多或超出“放盅前水位”線，有可能造成溢出及其他危險。
5. 使用過程中或會有水點由上蓋邊沿濺出，切勿將本產品置於其他電器或電源拖板附近使用，或令水點溢出在連接器上，以免引致火災、觸電或個人傷害。
6. 確保上蓋已完全關上，以防止水濺出或大量蒸氣噴出，或導致產品不能正常運作及產生危險。
7. **警告！** 在使用過程中或剛使用後，切勿打開上蓋以避免因高溫蒸氣於蒸氣孔排出而造成燙傷。
8. 盡量避免於運作中途打開上蓋，否則沸騰的水會濺出引致燙傷。如需打開上蓋，建議先按【功能/取消】鍵取消有關加熱功能或關掉產品。打開時，小心蒸氣孔及上蓋有倒汗水滴落。
9. 完成烹調後，上蓋及主機會有水珠(倒汗水)凝聚，此乃正常現象。避免凝聚水珠從上蓋或焗盅掉落至控制面板或電線位置，取出食物時，必先關掉產品及拔掉電源插頭，靜候數分鐘後再打開上蓋，以免被餘熱灼傷。避免被蒸氣燙傷，可使用隔熱手套。
10. 操作時，如需打開上蓋檢查食物，建議使用長把手的工具，亦避免將機體貼靠牆壁或傢具使用。
11. 當注水格沒有水時，切勿啟動本產品。若出現乾燒情況，請加水入注水格或拔出電源插頭。
12. 運作過程中，切勿移動或搖晃本產品，有可能引致大量蒸氣噴出，造成燙傷或其他危險。
13. 使用時，切勿用任何物件覆蓋本產品表面或遮擋蒸氣孔，以免造成產品故障、變形或變色。

1.3 使用後

1. 應先拔出電源插頭，待本產品冷卻後才進行移動和清潔。
2. 烹調時及剛完成烹調後，切勿立即接觸本產品或其發熱盤，避免被餘熱灼傷。
3. 切勿將機身、電源線或插頭浸入水中，或被水濺濕，以免影響本產品的安全性能及可能構成觸電危險。使用前，必須確保插頭已完全擦乾。
4. 使用後或長期不使用時，請拔下插頭，以免因絕緣老化而引致漏電及觸電危險。切勿以濕手接觸、插上或拔除插頭，否則有可能引致觸電。

1.4 安全注意事項

1. 本產品設有防乾燒功能。在沒有盛水情況下運作，如機內溫度到達或超出保護值，本產品會停止運作及顯示錯誤代碼。若產品曾乾燒，先關掉產品及拔掉電源插頭，待其完全冷卻後才可再次使用。**警告！**防乾燒功能屬安全保護裝置，**切勿**依賴此功能關機。
2. 切勿使用外置計時器或遙控系統操作本產品，以防短路及自燃等危險。
3. 切勿使燉盅承受太大的溫度變化(例如：用明火加熱燉盅或將灼熱的燉盅放在雲石面上或冷水中)，否則可導致燉盅因冷縮熱脹而爆裂。
4. 切勿使用本產品烹煮酸或鹼類食物，以免腐蝕產品的燉盅或發熱盤表面。
5. 燉盅屬易碎物品，必須小心使用，避免碰撞或從高處跌落而造成損毀。
6. 若有兒童在旁，須加倍小心使用本產品及看管兒童，以確保他們不會把本產品當作玩具。切勿讓兒童單獨使用、清潔及進行保養，並將本產品及其電線置於遠離他們可能觸及的地方。
7. 小心使用電源線，不可在電源線上放置重物或夾住電源線；不可改裝或用力拉扯或扭曲電源線；在拔出或插入插頭時，應用手握穩插頭，並確保將電源線與插座接駁良好。否則可能會引致危險。
8. 切勿在電源線纏結的情況下使用本產品，或將電源線懸掛在桌子、櫥櫃的邊緣或讓它接觸發熱的表面，否則會加快電源線的損耗。
9. 經常清理插頭上的塵埃，保持本產品清潔及不沾油污，特別是插頭的鐵片位置，以免引起火災的發生。
10. 切勿將本產品用於建議烹飪以外的其他用途。(否則，本產品有可能發生故障或危險。)
11. 本產品可供年齡在8歲或以上的兒童及體質、感覺或智力有障礙人士或缺乏經驗和相關知識的人士使用，但他們必須接受負責安全人士的監督或指導如何安全地使用產品和理解所涉及之危險。
12. 本產品是家用或在類似環境使用，如：商店內部、辦事處以及其他工作環境的員工廚房區域或類型的環境，切勿於戶外使用。
13. 經常檢查產品、燉盅、電源線及插頭。為避免危險，如發現任何損毀或曾經跌落，應立即停止使用，並聯絡信興電器服務中心有限公司進行檢查及維修。
14. 切勿擅自改裝產品或使用非生產商提供的零件進行修理，否則，可造成危險及維修保養無效。本公司將不會承擔任何損壞的維修責任及賠償。
15. 遵從安全守則及避免釀成意外，如需要維修本產品，請攜同本產品、產品保修記錄卡及收據到信興電器服務中心有限公司，地址印於本說明書的背頁或致電熱線查詢：2406 5666。

2. 清潔及保存

1. 清潔前，必須拔除電源插頭，並待產品完全冷卻。
2. 玻璃／陶瓷燉盅是易碎物品，使用及清洗時，請小心輕放，避免碰撞或讓玻璃／陶瓷燉盅經常處於高溫狀態。
3. 清洗燉盅時，可用溫水及少量中性清潔劑清洗。切勿使用有毒或含腐蝕性的清潔劑進行清潔。
4. 切勿用水直接清洗主機外殼，亦避免讓液體流入本產品，以免造成故障及危險。
5. 如欲清除食物殘存氣味，可注水入燉盅及注水格，啟動產品將水煮沸，然後將水倒掉，待冷卻後再用溫水清洗。
6. 使用數次後，發熱盤位置或會出現乳白色、啡色或黑色的圓點，這是由於水中含有礦物質。礦物經過加熱轉化成化合物，然後沉澱形成水垢。水的硬度愈高，水垢囤積速度愈快，此乃正常現象，不影響使用。
7. 如須清除注水格內的水垢，可參考以下方法處理：
 - 於注水格內注入清水(建議加水至最高水位線)；
 - 將半個切片檸檬放入注水格內(或按每100毫升2克檸檬酸比例加入)；
 - 選擇“自選”功能將水加熱至沸騰，然後關機靜候約20分鐘。將注水格內的水全部倒掉，然後用海綿或軟毛刷擦洗發熱盤位置。完成後，用水沖洗過淨。

注意！如發現有檸檬酸味殘留，可再次注水加熱至沸騰，然後將水倒掉即可。
8. 切勿用電油、去污粉或粗硬的潔具(如鋼絲刷)清潔。
9. 如發現注水格、機身上蓋有污穢，可用濕布抹淨，再抹乾。
10. 待產品完全冷卻及清洗後，才能存放入紙箱，然後儲存在乾爽的環境中。切勿用電源線纏繞在本產品四周或壓住電源線，避免做成電源線損壞。

3. 產品規格

型號	RSS-T08GC
額定電壓	220–240伏特~ 50赫茲
額定功率	300瓦
燉盅容量(約)	0.8升 (玻璃燉盅：0.3升) (陶瓷燉盅：0.5升)
淨重(約)	1.6 公斤
產品尺寸(闊 x 深 x 高)(約)	135 x 300 x 198毫米

4. 控制面板及產品結構

4.1 控制面板

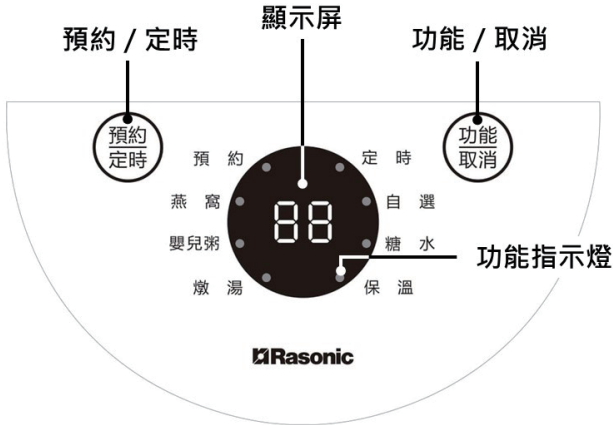

4.2 產品結構

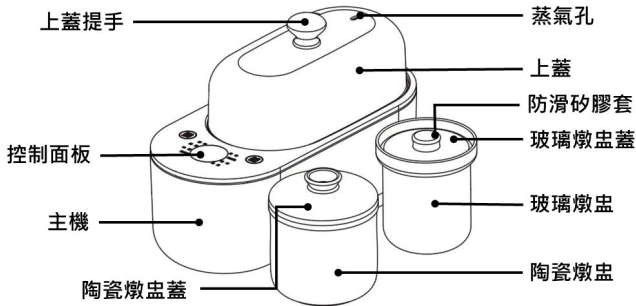

4.3 水位線標示

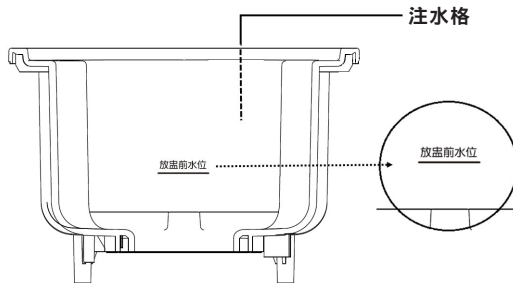

註：所有圖片僅作參考，尺寸比例或有差異，以實物為準。

功能運作時間表

✓ 支援
✗ 不支援

功能名稱	顯示屏顯示值	預設運作時間	可調校烹調時間範圍	每次調校增加時間	預約功能	可預約時間範圍	保溫功能
燕窩	20	20分鐘	10-30分鐘	5分鐘	✓	0.5-9.5小時	✓
嬰兒粥	1.3	1.3小時	0.5-9.5小時	0.5小時(30分鐘)	✓		✓
燉湯	1.2	1.2小時			✓		✓
糖水	1.5	1.5小時			✓		✓
自選	1.2	1.2小時			✓		✓
預約	2.0	2小時	不適用		✓		✓
保溫	— . —	不適用					

* 除燕窩功能顯示為分鐘值，其餘功能顯示為小時值。

* 燕窩功能運作時，每1的顯示值表示1分鐘；而其他功能運作時，每0.1的顯示值表示6分鐘。

5. 使用方法

5.1 首次使用

1. 初次使用時，產品或會有新包裝物料的味道，此乃正常現象。經數次使用後，味道會逐漸消失。
2. 確保電源插頭未被接上，並根據不同的情況，按照「[章節5.2預備工作](#)」及「[章節5.3操作說明](#)」使用本產品。

5.2 預備工作

注意！使用前，先用水徹底清洗玻璃／陶瓷燉盅。

注意！注水入注水格時，不可超過注水格的“放盅前水位”線；應使用蒸餾水或普通清水，切忌使用礦泉水，以免加快水垢形成。

注意！加入食材和水時，建議不可超過玻璃／陶瓷燉盅容量的80%，以防止大量水份溢出。

1. 將適量的食材和水加入玻璃／陶瓷燉盅，蓋好玻璃／陶瓷燉盅蓋；
2. 注水入注水格至“放盅前水位”線；
3. 將玻璃／陶瓷燉盅放入主機，最後蓋上上蓋。

注意！為避免倒汗水滴濕電源插頭，建議打開上蓋時垂直向上提起，然後倒置上蓋讓倒汗水流入內，藉此避免水滴掉落控制面板或電源線上。

5.3 操作說明

1. 接上電源後，產品會發出“Di”聲，顯示屏顯示“0.0”，表示產品進入待機模式。
2. 在待機模式狀態下，按【功能／取消】鍵選擇所需功能，功能會以燕窩 -> 嬰兒粥 -> 燉湯 -> 自選 -> 糖水 -> 保溫 -> 待機模式“0.0”順序循環顯示，對應功能指示燈會亮起及該功能的預設運作時間會於顯示屏閃亮。選定後，等候約6秒產品自動確認，對應功能指示燈變為長亮，顯示屏會顯示運作時間及“.”閃亮，產品便開始運作。當加熱過程達到預設溫度後，運作時間便開始倒數。

- 如需調整時間，在運作時間閃亮期間（約6秒內），可按【預約／定時】鍵調整運作時間，每按一次按鈕，時間會遞增（如功能的預設運作時間是1.2或1.3，時間會先到1.5後，再以0.5遞增），直至到該功能可調校時間範圍最大值後，再返回可調校時間範圍最小值，如此循環。具體時間範圍可參考「**章節4.2產品結構：功能運作時間表**」。完成後，等候約6秒以確認並開始運作。
- 完成烹調後，產品會發出“Di Di Di”聲3次提示用戶，顯示屏顯示“-.-”，“-.”閃亮及保溫功能指示燈亮起，產品自動進入保溫模式。
- 如用戶不需保溫功能，可於保溫期間按【功能／取消】鍵自行取消，顯示屏顯示“0.0”，產品會返回待機模式。
- 在操作過程中，用戶可隨時按【功能／取消】鍵取消設定把產品返回待機模式。

注意！建議等待約5分鐘方可打開上蓋及取出食物，避免被濺出的水燙傷。

注意！如運作過程中或保溫過程中水份完全蒸發，產品會發出“Di Di Di”聲4次，顯示屏會出現故障代碼“E3”，產品將停止運作。用戶須待產品充定冷卻直至溫度低於保護值再須重新接上電源才可繼續使用本產品。

5.4 預約功能(預約產品開始運作時間)

根據使用方法，按「**章節4.2預備工作**」的指示放置清水及食材於玻璃／陶瓷燉盅，然後按以下步驟設定理想的預約時間。

注意！容易變質的食物不建議設定過長預約時間，避免食材變質。

- 在待機模式狀態下，按【預約／定時】鍵，預約功能指示燈會亮起及預設時間“2.0”會於顯示屏閃亮，如6秒內沒有任何操作，產品將返回待機模式。
如需調整時間，在預約時間閃亮期間（約6秒內），可再按【預約／定時】鍵調整預約時間。
- 時間選定後，可按【功能／取消】鍵選擇所需功能，於6秒內沒有任何操作，產品將返回待機模式。
- 功能選定後，可按【預約／定時】鍵調整烹調運作時間或等候約6秒作確認該預設運作時間。完成設定後，對應功能、預約功能及定時功能指示燈變為長亮，表示預約功能設定完成。顯示屏會顯示預約時間及“-.”閃亮，產品開始倒數計時。

注意！完成預約功能設定後，無法更改功能及調整時間。

例子：預約1小時後，開始30分鐘“燕窩”功能

- 接上電源後，顯示屏顯示“0.0”，產品進入待機模式；
- 按【預約／定時】鍵，預約指示燈亮起，顯示屏顯示預設時間“2.0”(2小時)。按【預約／定時】鍵調校預約時間至“1.0”(1小時)。
- 按【功能／取消】鍵選擇“燕窩”功能，對應功能指示燈亮起，顯示屏顯示“燕窩”預設運作時間“20”(20分鐘)。按【預約／定時】鍵調校運作時間至“30”(30分鐘)。
- 完成設定後，等候約6秒以確認有關設定，預約指示燈亦會亮起，預約功能完成。
- 約1小時後，預約指示燈會熄滅，“燕窩”功能會開始運作30分鐘，直至烹調程序完成。完成後，產品會發出“Di Di Di”聲3次，顯示屏顯示“-.-”，“-.”閃亮及保溫功能指示燈亮起，產品自動進入保溫模式。
- 保溫功能會一直運作，直至注水格的水完全蒸發。(具體運作可參考「**章節5.5保溫功能**」)

5.5 保溫功能

烹調完成後，產品將自動進入保溫狀態。此功能並沒有預定的完結時間，產品會一直保溫直至注水格的水份完全蒸發。

如需獨立開啟保溫模式，用戶可按【功能／取消】鍵選擇“保溫”功能，保溫功能指示燈亮起，顯示屏顯示“—.”。等候約6秒以確認該設定，產品會進入保溫功能，顯示屏“—”亮起，“.”閃亮。

運作過程中，如須取消保溫功能，可按【功能／取消】鍵取消，顯示屏顯示“0.0”，產品會返回待機模式，用戶可待產品冷卻後拔出電源插頭。

注意！切勿將易變質的食物保溫過長的時間，否則可能導致食物變質。

注意！當產品出現缺水，產品會發出“Di Di Di”聲4次，顯示屏會出現故障代碼“E3”，產品將停止運作。用戶須待產品充分冷卻直至溫度低於保護值再須重新接上電源才可繼續使用本產品。

5.6 取消功能

運作過程中，如需取消有關烹調功能，按【功能／取消】鍵，顯示屏顯示“0.0”，該烹調功能將會取消，產品將會返回待機模式。

6. 故障排除

如出現以下異常情況或故障，應立即停止使用本產品，並將本產品送往信興電器服務中心有限公司進行檢查及維修。

1. 電源線或電源插頭異常發熱。
2. 稍微屈曲電源線，產品即時出現斷續通電的情況。
3. 產品異常發熱、釋出燒焦味道或冒煙。
4. 當接觸產品的外殼，有感覺到觸電情況。
5. 有部分時間無法自行斷電。
6. 產品出現漏水情況。

故障現象	檢查要點／故障原因	處理方法
接通電源後，產品沒有反應。	是否停電？	待電力恢復後使用。
	電源線插頭是否鬆脫？	根據檢查要點小心檢查。如有需要，請聯絡信興電器服務中心有限公司進行檢查及維修。
故障代碼 E1	熱敏電阻斷路	請聯絡信興電器服務中心有限公司進行檢查及維修。
故障代碼 E2	熱敏電阻短路	請聯絡信興電器服務中心有限公司進行檢查及維修。
故障代碼 E3	容器有沒有足夠的水？	拔掉電源，加入適當的水後，重新接上電源及使用產品。

7. 特別聲明

1. 本資料上所有內容經過核對，如有任何印刷及內容上的誤解，本公司將保留解釋權。
2. 本產品若有技術改進，會編進新版說明書中，恕不另行通知；如產品外觀、顏色及規格有改動，則以製造商生產資料為準。
3. 如本資料之中英文版本有差異時，應以中文版為準。
4. 使用說明書的電子副本可以通過電子郵件發送致客戶，如有需要，可致電信興電工工程有限公司：2861 2767。

8. 售後服務

1. 由購買收據起之一年保修期內，經信興電器服務中心有限公司之服務人員證實產品故障屬正常使用發生者，本公司將提供免費維修或更換零件服務。經更換之任何損壞／毀零件，將屬本公司所有。保修範圍不包括修理或更換損耗性零件和配件(包括玻璃／陶瓷燉盅、玻璃／陶瓷燉盅蓋、防滑矽膠套、上蓋及電源線等)。如使用不當，或作(半)商業用途，或未依照說明書使用，保修服務將無效，本公司將不會承擔任何損壞的維修及賠償。
2. 用戶必須於維修時出示購買／換購收據及蓋有銷售點／換購中心印章的產品保修記錄卡，如有任何疑問，請致電信興電器服務中心有限公司熱線查詢：2406 5666。

Thank you for choosing Rasonic Mini Electric Stewing Mug. Please read the operation manual carefully before use and keep it for your future reference.

Table of Content

1. Important Safeguards
2. Cleaning and Storage
3. Product Specifications
4. Control Panel and Product Structure
5. Operation Instructions
6. Troubleshooting and Treatment
7. Special Avowal
8. After Sales Service

1. Important Safeguards

When using the appliance, make sure to follow the below safety precautions:

1.1 Before use

1. Read the following safety precautions before using the appliance. Failure or negligence in following these safety precautions could cause fire, electrical shock or injury.
2. Remove and discard all packing materials of the appliance. Make sure children do not play with them to avoid any danger.
3. Before connecting to the electricity, check if the rated voltage on the appliance corresponds to the local voltage. To avoid overload, do not connect the appliance in the same power socket with other high power consumption appliances. Make sure the appliance is connected to power socket with grounding.
4. To avoid any hazard, make sure the surface of the appliance and plug is dry before use.

1.2 In operation

1. Never leave the appliance unattended when in use or operate without water.
2. Do not cook inside the water tank (heating plate) directly.
3. Do not operate the appliance in the following places:
 - Humid environment or near water sources
 - Near heat and fire sources (such as electric oven and induction cooker etc.)
 - Unstable and insufficient support surface
 - Near inflammable or non-resistant to heat objects (e.g. carpet, plastic table cloth, curtain and towel etc.)
4. Sufficient room must be reserved for steam or air bubbles generated, and amount of water should not exceed the maximum water level “放盞前水位” of the water tank. Otherwise, water and steam may spill out during operation and cause dangers.
5. Water may splash out from the edge of lid during operation. To avoid fire, electrical shock or injury, do not operate the appliance near the other appliances, electric socket extension and avoid spillage on the connector.

6. Make sure the lid is closed tightly to prevent water from splashing out or steam discharging; otherwise, the appliance may not function properly or cause hazards.
7. **WARNING!** Do not open the lid during operation or right after use, as massive steam will come out from the steam vent, only by doing so can prevent steam burn.
8. Do not open the lid during operation, otherwise boiled water may spill out and cause burns. If necessary, press [Keep Warm/Cancel] button to switch off the appliance before open the lid. Be careful of the hot steam and droplets when open the lid.
9. After cooking, a lot of vapour and water droplets will remain inside the main unit and lid, which is a normal phenomenon. To avoid burns, switch off the appliance and unplug the power, wait for a while before opening the lid to avoid burn by residue heat. Open the lid carefully to avoid condensed water droplets from the lid drop onto the control panel or power cord. To avoid scalding by hot steam, use oven mitts to pick up the food from the appliance.
10. Always use kitchen utensils with long handles when checking the food inside. Beware of hot steam, do not operate the appliance next to wall or furniture.
11. Do not switch on the appliance when there is no water in the water tank. If boil dry occurred, add water into the water tank or unplug the power.
12. Do not open the lid, move or shake the appliance during operation as to avoid massive steam emission resulting in burns or other hazards.
13. To avoid appliance malfunction, deformation or discoloration, do not cover the appliance or steam vent by any object when using the appliance.

1.3 After use

1. Normally cleaned after use, unplug the appliance from the socket and let the appliance cool down before moving and cleaning.
2. To avoid getting burned, never touch the appliance enclosure and heating plate which are subject to residual heat right after use.
3. To avoid affecting the safety performance and prevent electric shock and fire, never immerse the main body, power cord or plug in water or let them wet. Make sure the plug is dry before use.

4. Disconnect the power plug after use or, when the appliance not in use for long time, preventing electric leakage and electric shock due to insulation degeneration. Do not touch, plug or unplug the appliance by wet hands which can result in electric shock.

1.4 Beware of the following

1. The appliance equipped with boil-dry protection system. If water inside the water tank completely evaporated or temperature exceeds the protection level, the operation will stop while error code will show on display. If the appliance was boiled dry once, switch off and lift the main body from the power base and cool down completely before reuse. **WARNING!** Boil-dry protection is the device for protection. **Do not** rely on this function to switch off the appliance.
2. The appliance is not intended to be operated by means of an external timer or separated remote control system, as to prevent short-circuit or other flammable hazards.
3. Do not let the stewing mug withstand big temperature difference. (For example: Heat the stewing mug with fire or put the hot stewing mug on a marble surface or into cold water), otherwise the mug may crack because of thermal expansion and contraction.
4. To prevent corrosion on water tank and stewing mug, avoid cooking any substance that is acidic or alkaline.
5. The stewing mug is a kind of fragile ware. Use it carefully. Do not hit the mug or drop it from a high place to avoid damage.
6. Great care is necessary in using the appliance, especially near children. Children should be supervised to ensure that they do not play with the appliance. Also, children without adult supervision should not operate, clean and maintain the appliance. Keep them away from the appliance and its power cord.
7. Handle the power cord with care. Do not place heavy objects on the power cord. Never clip, modify, stretch or twist the power cord. Do not grasp the power cord but the plug itself when plug in or unplug the appliance. Ensure that the power plug fits all the way into the appliance socket, fail to do it may cause electric hazard.
8. Do not operate the appliance when the power cord is tangle or hang over the edge of a table, countertop or let it touch any hot surface. It may cause power cord damage.

9. Always wipe off any dust from the power plug and clean the appliance, make sure it is not oily, especially on the pins such to prevent fire from happening.
10. Do not use the appliance for purposes other than cooking. (If the appliance is not used for cooking, it may cause malfunction and hazard.)
11. The appliance can be used by children aged from 8 years and above and persons with reduced physical, sensory or mental capabilities, or lack of experience and knowledge, if they have given supervision or instruction concerning use of the appliance in a safe way and understand the hazards involved.
12. The appliance is intended to be used in household or similar applications such as staff kitchen areas in shops, offices and other working environments. Do not use it outdoors.
13. Always check the condition of the appliance, stewing mug, power cord and plug. To avoid hazard, stop using the appliance immediately if the appliance is damaged or dropped. Contact Shun Hing Electric Service Centre Limited for checking and repairing.
14. Do not use, replace or assembly any parts which is not produced under authorization, otherwise, the warranty becomes invalid and our company will refuse any liability and repairing cost for the damage caused.
15. To comply with safety regulations and avoid hazards, if repair is needed, present the official invoice, product warranty card with the appliance for repair service and contact Shun Hing Electric Service Centre Limited hotline at 2406 5666. Address can be found at the back page of the manual.

2. Cleaning and Storage

1. Before cleaning, unplug the appliance and let it cool down completely.
2. Stewing mug is a kind of fragile ware, handle with care and do not place in high temperature environment for a long time.
3. Use warm water together with mild detergent to clean the stewing mug. Never use poisonous or corrosive detergent for cleaning.
4. To avoid malfunction and dangers, do not clean the main body with water directly or let water penetrate inside the main body.

5. To remove the odor, add some water to the stewing mug and the water tank, turn on the appliance until water boiled. Pour out the water and wait until the appliance cool down completely. Then wash it with warm water.
6. Due to the minerals in water, colored water scale will be found on the heating plate after heating. The harder the water, the quicker the scale will be formed. It is a normal phenomenon and will not affect the operation.
7. To remove the water scale, follow the below instructions:
 - Fill water into the water tank (fill water to the maximum water level mark is recommended)
 - Put halved sliced lemon in the water tank (or follow the ratio to add 2g citric acid per 100ml water).
 - Operate "Optional" function until the water boiled. Press the [Function/Cancel] key to stop the operation, wait and pour out all water after around 20 minutes. Then clean the heating plate with a sponge or soft brush, and rinse by water at the end.

NOTICE! To remove the remaining smell of citric acid, boil water again and pour it out afterward.

8. Never clean the appliance by using gasoline, cleanser or harsh cleaning tools (e.g. metal brush).
9. If dirt is attached on the water tank, main body or lid, use a damp cloth to clean and wipe them dry.
10. Always let the appliance cool down completely before storage. Put it in a paper box and store in a dry environment. Never wrap the power cord tightly around the appliance or put pressure on it to avoid the power cord damage.

3. Product Specifications

Model No.	RSS-T08GC
Rated Voltage	220-240V~ 50Hz
Rated Power	300W
Stewing Mug Capacity (Approx.)	0.8L (Glass Mug: 0.3L) (Ceramic Mug: 0.5L)
Net Weight (Approx.)	1.6 kg
Product size (W x D x H) (Approx.)	135 x 300 x 198mm

4. Control Panel and Product Structure

4.1 Control Panel

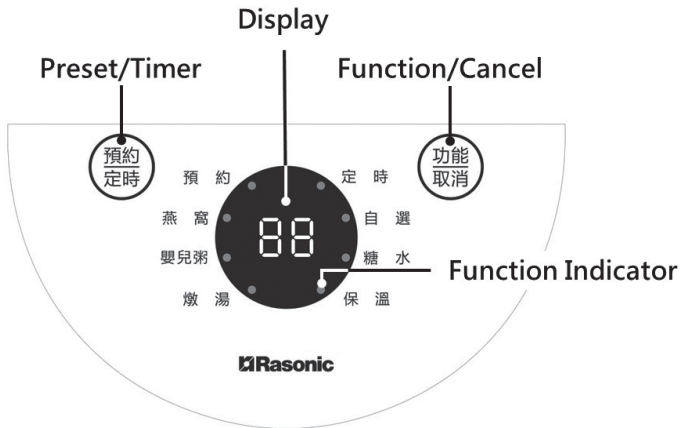

4.2 Product Structure

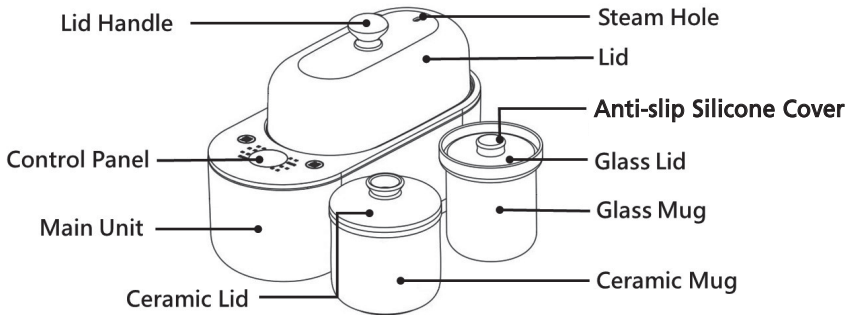

4.3 Water Level Mark

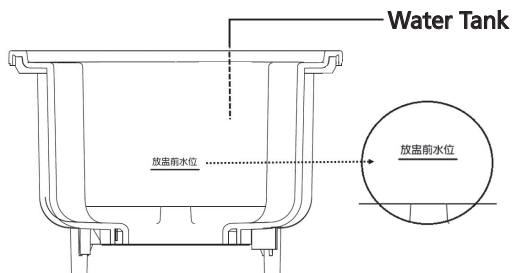

Remarks: The above illustrations are for reference only and subject to the actual appliance.

Operation Time Table

Function	Preset on display	Operation time	Adjustable cooking time range	Time increase per adjusted	Preset function	Preset time range	Keep warm function
Bird's nest (燕窩)	20	20 mins	10-30 mins	5 mins	✓	0.5-9.5 hrs	✓
Baby congee (嬰兒粥)	1.3	1.3 hrs	0.5-9.5 hrs	0.5 hrs (30 mins)	✓		✓
Double-boiled soup (燉湯)	1.2	1.2 hrs			✓		✓
Chinese Dessert (糖水)	1.5	1.5 hrs			✓		✓
Optional (自選)	1.2	1.2 hrs			✓		✓
Preset (預約)	2.0	2 hrs			✓		✓
Keep Warm (保溫)	--	N/A					

- * Except for the bird's nest function, which is displayed in minute, all other functions are displayed in hour.
- * When the bird's nest function is working, every 1 means 1 minute, and other functions are working, every 0.1 means 6 minutes.

5. Operation Instructions

5.1 Before First Use

1. When the first time of use, it may have smell due to the new packing. It is a normal phenomenon where the smell will gradually disappear with time.
2. Make sure the appliance is not plugged. Depend on the cooking functions, follow the instruction stated in "Chapter 5.2 Preparation" and "Chapter 5.3 Function Selection" to operation the appliance.

5.2 Preparation

CAUTION! Clean the glass/ceramic mug thoroughly by water before using.

CAUTION! Do not exceed the maximum water level "放盅前水位" of the water tank when filling water. Only use distilled water or tap water, never use mineral water as it will fasten the formation of scale.

CAUTION! When adding ingredients and water, it is recommended not to exceed 80% of the glass/ceramic mug capacity to prevent water may spill out during operation.

1. Put appropriate amount of ingredients and water into the glass/ceramic mug supplied, and close the glass/ceramic lid.
2. Add water to the maximum water level "放盅前水位" of the water tank.
3. Place the glass/ceramic mug into the main unit, and close the lid finally.

CAUTION! To avoid the power plug from getting wet by the water droplets, lift the lid vertically when open. To avoid water droplets dripping off onto the power cord and control panel, upside down the lid when lifting and let water droplets backflow to the lid.

5.3 Function Selection

1. After connecting to the electricity, a “Di” sound will be heard. The display will show “0.0” representing the appliance is in the standby mode.
2. In the standby mode, Press [Function/Cancel] key to select desired function where Bird’s nest (燕窩) -> Baby congee (嬰兒粥) -> Double-boiled soup (燉湯) -> Optional (自選) -> Chinese Dessert (糖水) -> Keep Warm (保溫) -> Standby mode “0.0” will show in order. Function indicators will light up accordingly while default operation time will show on the display. After selected, wait for about 6 seconds to confirm the relevant settings, the display will show the operation time and “. .” keeps flashing. When the preset temperature is reached during the heating process, the operation time will start to count down.
3. When the operation time is flashing (within about 6 seconds), Press the [Preset/Timer] key to adjust the operation time. While button is pressed every time, time value will be increased (If the preset operating time of the function is 1.2 or 1.3, the time will first reach 1.5, and then increase by 0.5), until the function adjusts to the maximum time value, and then return to minimum time value, and sequential cycles. Detailed information can be found in “**Chapter 4.2 Product Structure: Operation Time Table**”. After completion, wait for about 6 seconds to confirm the relevant settings.
4. When the operation completed, “Di Di Di” sounds will be emitted 3 times to remind user. “-.-” will show on display, “. .” keeps flashing, and keep warm indicator will light up. The appliance will switch to keep warm mode automatically.
5. If no keep warm function is needed, press the [Function/Cancel] key to cancel during warm keeping. “0.0” will show on display and the appliance will return to the standby mode.
6. During the operation, the user can press [Function/Cancel] key to cancel at any time, and the appliance will return to the standby mode.

CAUTION! Suggested to wait for about 5 minutes before opening the lid and taking out the food, as it can avoid burns by water spilling.

CAUTION! The appliance will automatically stop operation if water inside the water tank evaporated during operation or warm keeping. The appliance will emit “Di Di Di” sounds 4 times and “E3” will show on display at the time when the operation suspended. The user must wait for the appliance to fully cool down until the temperature drops below protection value, and then reconnect the power supply before continuing to use the appliance.

5.4 Preset function (The time to start the operation)

Follow the procedures described in “**Charter 5.2 Preparation**”, place the ingredients and clean water into the glass/ceramic mug, and follow the steps below to preset the cooking function.

CAUTION! Perishable foods are not recommended for long preset time as to avoid deterioration.

1. In the standby mode, press the [Preset/Timer] key, the preset indicator will light up and the preset time “2.0” will flash on the display. If there is no operation within 6 seconds, the appliance will return to the standby mode.
During the flashing of the preset time (within about 6 seconds). Press the [Preset/Timer] key again to adjust the preset time.
2. After preset time is set, press the [Function/Cancel] key to select desired function. If there is no operation within 6 seconds, the appliance will return to the standby mode.
3. After function is selected, press the [Preset/Timer] key to adjust the function cooking operation time or wait for about 6 seconds to confirm the preset function time. The corresponding preset and timer indicators will light up, the preset function setting completed. The display will show the operation time and “. .” keeps flashing.

CAUTION! After completing the preset function setting, the function and time cannot be adjusted.

For example: Preset 1 hour to start the “Bird’s nest” function for 30 minutes.

- After connecting to the electricity, “0.0” will show on the display representing that the appliance is in the standby mode.
- Press the [Preset/Timer] key once, the preset indicator will light up and the default preset time “2.0” (2 hours) will show on display. Press the [Preset/Timer] key to adjust the time setting to “1.0” (1 hour).
- Press the [Function/Cancel] key to select the “Bird’s nest” function, corresponding indicator will light up. Display will show the default cooking time “20” (20 minutes). Press the [Preset/Timer] key to adjust the cooking time setting to “30” (30 minutes).
- After setting completed, wait for about 6 seconds to confirm the setting and “Preset” function will start.
- After around 1 hour, preset indicator will light off, “Bird’s nest” function will start for 30 minutes until the operation completed. “Di Di Di” sounds will be emitted 3 times, “-.-” will show on display, “. ” keeps flashing and keep warm indicator will light up. The appliance will switch to keep warm mode automatically.
- Warm keeping will continue until water inside the water tank evaporated. (Detailed information can be found in “**Chapter 5.5 Keep Warm Function**”.)

5.5 Keep Warm Function

The appliance will change to keep warm mode automatically after the operation completed. No defined operation time for warm keeping, so the appliance will turn off until the water inside the water tank evaporated.

User can press the [Function/Cancel] key to select “Keep Warm” function, related indicator and “-.-” will show at the same time. Keep warm function will start operating after 6 seconds, “-.-” light up on the display and “. ” keeps flashing.

If keep warm function is not necessary during operation, press the [Function/Cancel] key once, “0.0” will be shown on display representing the appliance is in the standby mode. User can unplug the appliance from the socket after the appliance cool down.

ATTENTION! Do not warm perishable foods for too long, otherwise, it may generate odor and get deteriorated.

CAUTION! When the appliance is out of water, “Di Di Di” sounds will be emitted 4 times and error code “E3” will be shown on display, the appliance will then turn off automatically. The user must wait for the appliance to fully cool down until the temperature drops below protection value, and then reconnect the power supply before continuing to use the appliance.

5.6 Cancel Function

User can press the [Function/Cancel] key to cancel the function. All the operation will be cancelled. “0.0” will show on display and the appliance will return to the standby mode.

6. Troubleshooting and Treatment

If the following situation happens, unplug the appliance immediately. Contact and report to Shun Hing Electric Service Centre Limited for checking and repairing.

1. If the power cord or power plug is abnormally hot.
2. If the electricity flows discontinuously when the power cord is bent.
3. If the appliance is abnormal hot, and scorching smoke or smoke.
4. If you get shocked when touching the appliance.
5. If the appliance sometimes does not turn off automatically.
6. If water is leaking out from the appliance.

Symptoms	Check Points/Reason	Remedy
After connected to the electricity, no respond with the appliance.	Is the power suspension?	Use the appliance after electricity resumed.
	Is the power plug not firmly connected to the socket?	Check the root cause carefully. If the problem cannot be fixed, contact Shun Hing Electric Service Centre Ltd. for checking and repairing.
Error Code E1	Open circuit of the thermistor	Contact Shun Hing Electric Service Centre Ltd. for checking and repairing.
Error Code E2	Short circuit of the thermistor	Contact Shun Hing Electric Service Centre Ltd. for checking and repairing.
Error Code E3	Does the container have enough water?	Unplug the power supply, add appropriate water, reconnect the power supply and use the appliance.

7. Special Avowal

1. The content in the operation manual has been checked. Our company reserves the hermeneutic power to any printing errors or misunderstanding on the content.
2. If there are technical improvements on the appliance, the operation manual will be updated in new version without prior notice. The product appearance, color and specification are subject to the manufacturer information.
3. In case there is any inconsistency or conflict between the English versions and Chinese versions of the terms, the Chinese versions shall prevail.
4. E-copy of user manual can be sent by e-mail on request, please call Shun Hing Electric Works & Engineering Co., Ltd. at 2861 2767.

8. After Sales Service

1. For any defect, in the judgment of technician from Shun Hing Electric Service Centre Limited, caused under normal use, our company is responsible for repairing or replacing any parts of the said electrical appliance free of charge within one year guarantee period commencing from the date of purchase. Any defective part which has been replaced shall become our property. Warranty service does not cover the repair or replacement of consumable parts (including glass / ceramic mug, glass / ceramic lid, lid and power cord, etc.). If the appliance is used improperly, for commercial (or semi-commercial) use, or not following the instructions in the operation manual, the warranty becomes invalid and our company will refuse any liability and repairing cost for the damage caused.
2. User must present the official invoice/redemption voucher and the product warranty card with the chop from sales point/redemption center for maintenance. For enquiries, please call Shun Hing Electric Service Centre Limited hotline at 2406 5666.



SHUN HING GROUP
信興集團
SINCE 1953

 **Rasonic 樂信牌**

信興電工工程有限公司

SHUN HING ELECTRIC WORKS AND ENGINEERING CO., LTD.

辦公室：香港九龍尖沙咀東部麼地道67號半島中心9樓

電話：2861 2767

圖文傳真：2865 6706

網址：<http://www.rasonic.com>

電郵：shew@shunhinggroup.com

Office: 9/F, Peninsula Centre, 67 Mody Road, Tsimshatsui East, Kowloon, Hong Kong

Tel: 2861 2767

Fax: 2865 6706

Website: <http://www.rasonic.com>

E-mail: shew@shunhinggroup.com

保養及維修 Maintenance and Repair Service:

信興電器服務中心有限公司

SHUN HING ELECTRIC SERVICE CENTRE LTD.

香港新界葵涌勝耀街2號信興中心11樓

電話：2406 5666

圖文傳真：2408 0316

網址：<http://www.shesc.com/zh>

11/F, Shun Hing Centre, 2 Shing Yiu Street, Kwai Chung, N.T. HK

Tel: 2406 5666

Fax: 2408 0316

Website: <http://www.shesc.com/zh>

客戶服務中心：

香港新界葵涌勝耀街2號信興中心1樓

九龍尖沙咀東部麼地道67號半島中心B座9樓

香港天后琉璃街7號柏景中心22樓

澳門慕拉士大馬路193-199號南嶺工業大廈5樓I座

有關最新之香港及澳門客戶服務中心資料，請參閱信興服務中心網址：<http://www.shesc.com/zh>

Customer Service Centre

1/F, Shun Hing Centre, 2 Shing Yiu Street, Kwai Chung, N.T.

9/F., Block B, Peninsula Centre, 67 Mody Road, Tsim Sha Tsui East, Kowloon

22/F, Parkview Centre, 7 Lau Li Street, Tin Hau, Hong Kong

Avenida de Venceslau de Morais, No. 193-199, 5 andar - I, Edf. Industrial Nam Leng, Macau

For the latest information of Hong Kong and Macau service center, please visit <http://www.shesc.com/en>